

DYNAMIC, TRANSVERSE COMPRESSION

Lapidus Plates

CoLink XP Plating System



Lapidus Std., +1 and +2mm

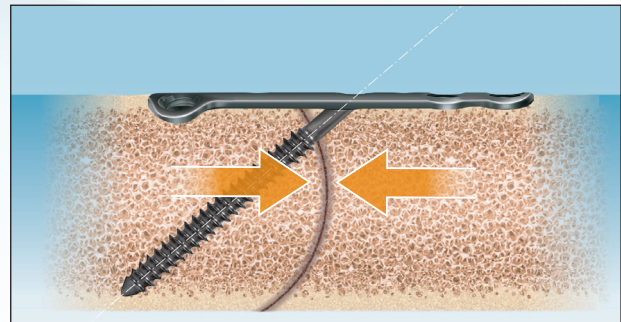
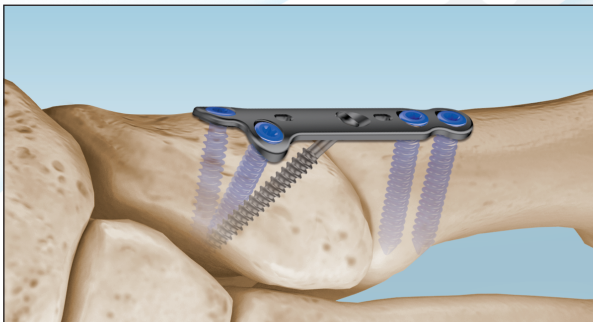

Low Profile, Anatomic Design, Type II Anodized

Mechanical Compression Designed to Stimulate the Fusion Process



A GLOBAL EXTREMITY COMPANY

Lapidus Plates

CoLink XP Plating System

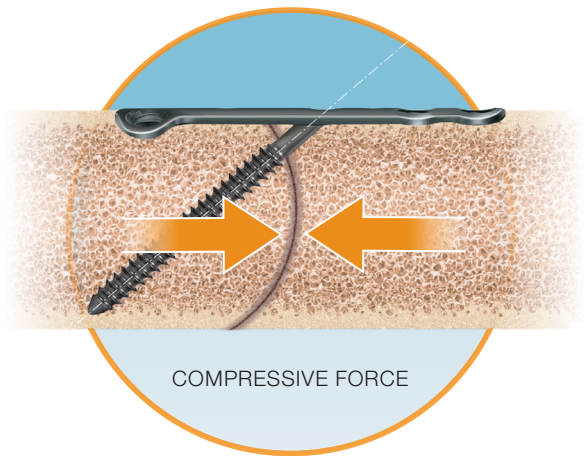
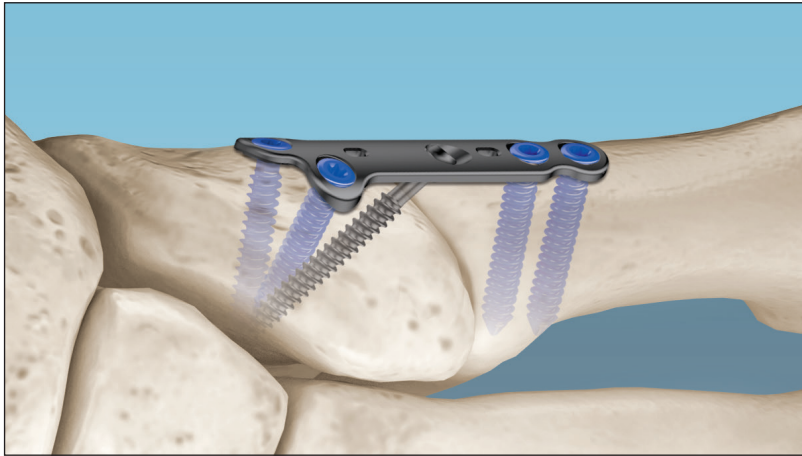

Dynamic, Transverse Compression

Use of the Transverse, Cross-joint Screw provides mechanical compression across the fusion site and to stimulate the fusion process.



Lapidus Std., +1 and +2mm

Surgical Technique

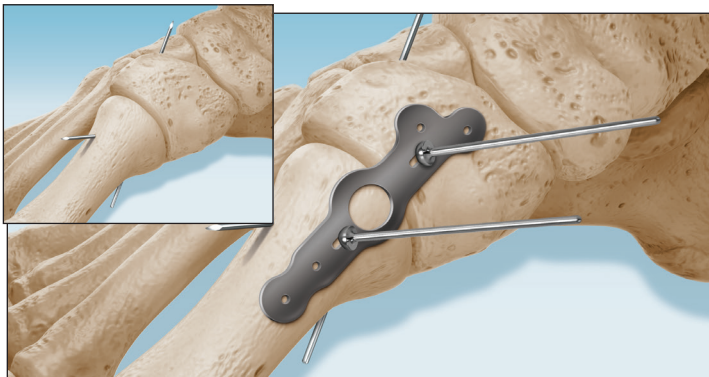

PROVISIONAL PLACEMENT & TRIAL PLATE EVALUATION

After the appropriate incisions, reduce the fragments and temporarily fix using cross-joining fixation pins. Position plate trial to confirm placement.

NOTE: Choose the correct plate. (Std, 1mm Step, 2mm Step).

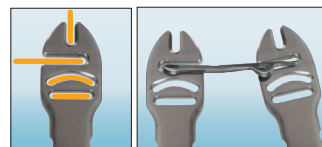
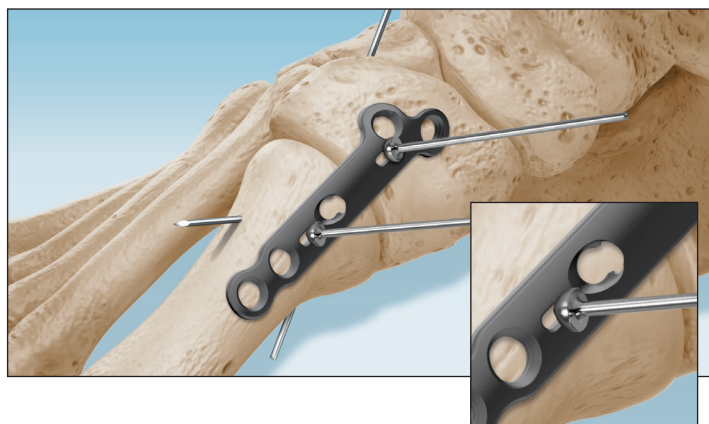
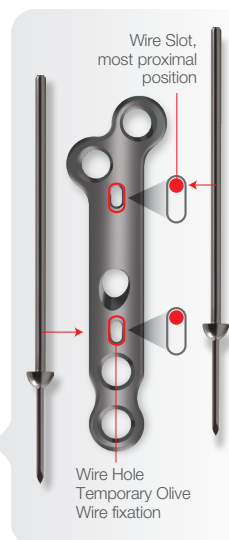
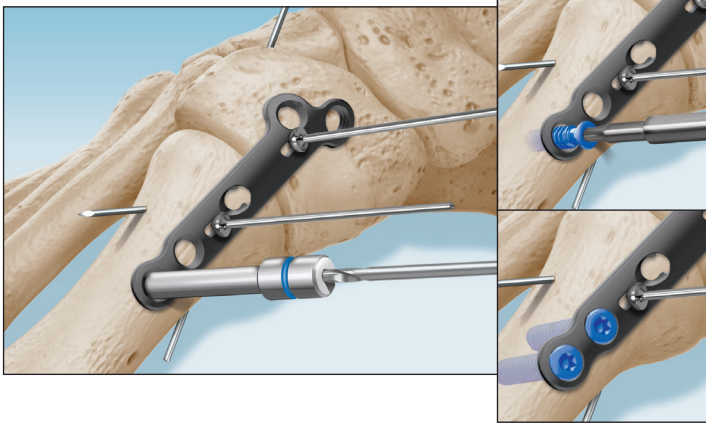

PLATE PREP AND POSITIONING

Once the correct Plate has been determined, open the sterile package to retrieve the Sterile Plate. If necessary bend the Plate to the required shape using the Plate Benders provided within the Instrument Set. Do not bend the Plate across any Screw holes. Plates should only be bent in one direction. Never re-bend Plates. Temporarily fix in place with the Olive Wires in the Wire Slots. Position the distal Olive Wire in the most proximal placement in the Wire Slot.





SCREW PREP

Begin Screw placements with the most distal hole and follow the suggested sequence at right. NOTE: All Plate Screw holes can accommodate both locking and non-locking screws (3.0mm and 3.5mm diameter). The Transverse Hole can only accommodate a 3.0mm Transverse Lag Screw.

- 3.0/3.5mm Locking/
Non-locking option ○
- 3.0mm Transverse
ONLY ○

SCREW SIZE & SEQUENCE

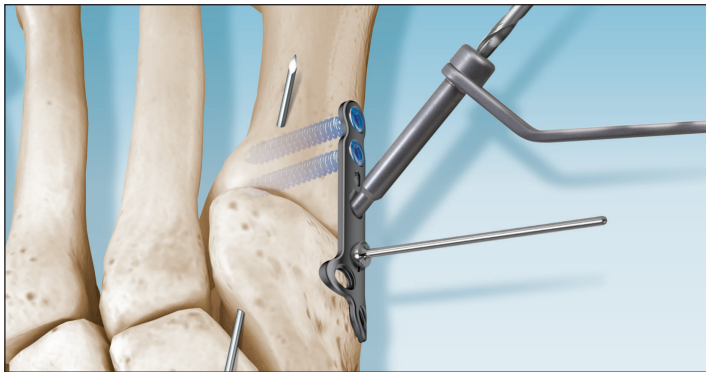

TRANSVERSE SCREW PREP

Once the most proximal screws are in place, the Transverse Drill Guide can be used to prepare the Transverse screw hole. For optimum lag screw orientation, ensure the Drill Guide is seated completely in the Transverse hole. Correct placement is with Handle vertical (90°) to plate with Screw trajectory at ~40° to plate.

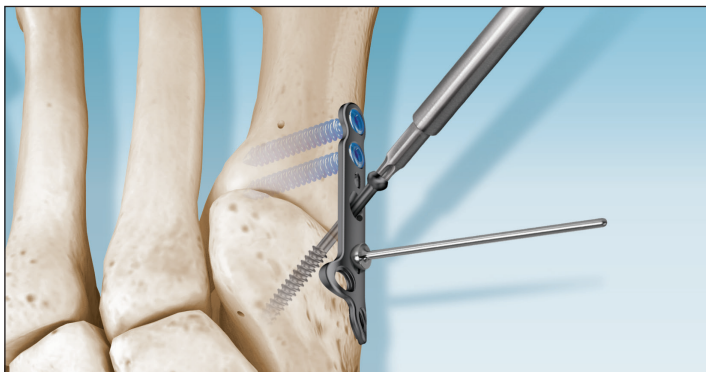
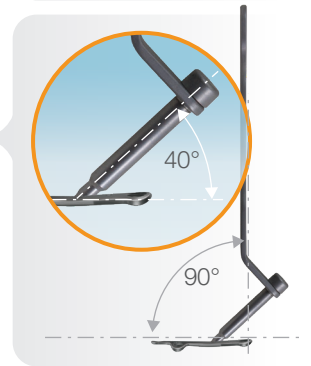

MEASURE TRANSVERSE SCREW LENGTH

Use the Laser Markings on the provided Reamer with the provided Drill Guide for correct Transverse Screw length. OPTIONAL: The provided Depth Gauge can be used, however the depth reading must be adjusted -2mm to compensate for the space between Depth Gauge on Plate surface and actual bone surface. NOTE: Also, a Screw length subtraction of 1-2mm may be required if the joint is not completely reduced when the measurement is performed.

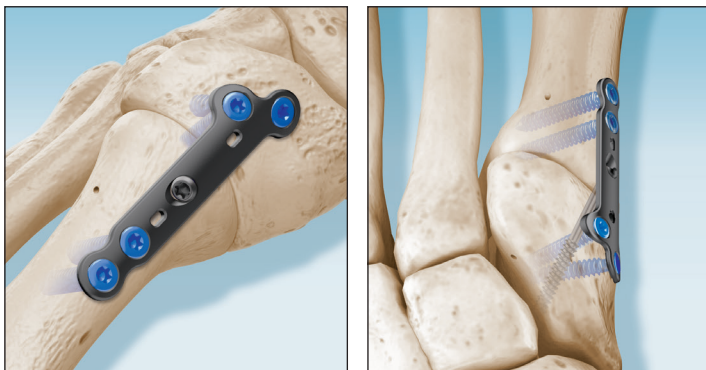
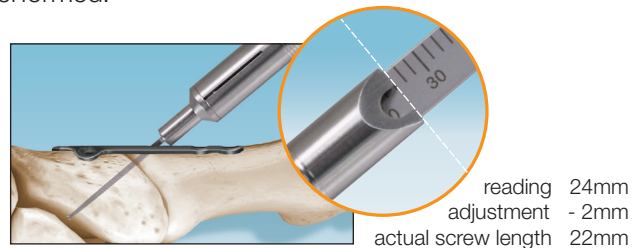

TRANSVERSE SCREW INSERTION / COMPRESSION

The lag screw should be tightened in a clock-wise motion. Once the joint is compressed, the remaining proximal screws are inserted and all temporary fixation wires are removed.

DYNAMIC, TRANSVERSE COMPRESSION

Lapidus Plates

CoLink XP Plating System



CoLink™ Lapidus Plates

- P40 ST145... Lapidus Plate XP, Std., Right
- P40 ST245... Lapidus Plate XP, Std., Left
- P40 ST155... Lapidus Plate XP,+1 mm, Right
- P40 ST255... Lapidus Plate XP,+1 mm, Left
- P40 ST165... Lapidus Plate XP,+2 mm, Right
- P40 265 Lapidus Plate XP,+2 mm, Left



CoLink™ Y Plate

- P40 ST055... Y-Plate, 5-Hole



CoLink™ Universal Plates

CATALOG NO..... DESCRIPTION

- P40 ST012... Universal Plate, 2-hole
- P40 ST013... Universal Plate, 3-hole
- P40 ST014... Universal Plate, 4-hole
- P40 ST015... Universal Plate, 5-hole
- P40 ST016... Universal Plate, 6-hole

P04 S0001.....CoLink™ Disposable Sterile Instruments for 3.0/3.5 Screws; Drills, Olive Wires, Guide Pins

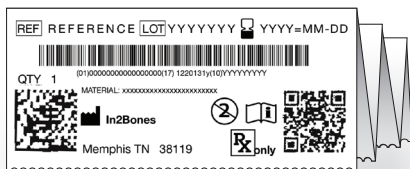
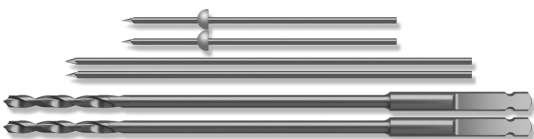

Traceability

The Implant package includes Unique Device Identification labeling, a series of self-adhesive labels for convenient and comprehensive implant traceability for hospital and patient records.

CoLink™ Plate Screw Non-Locking

CATALOG NO	DIA x LENGTH, STYLE
V30 ST208 ...	3.0 x 8mm, Non-Locking
V30 ST210 ...	3.0 x 10mm, Non-Locking
V30 ST212 ...	3.0 x 12mm, Non-Locking
V30 ST214 ...	3.0 x 14mm, Non-Locking
V30 ST216 ...	3.0 x 16mm, Non-Locking
V30 ST218 ...	3.0 x 18mm, Non-Locking
V30 ST220 ...	3.0 x 20mm, Non-Locking
V30 ST222 ...	3.0 x 22mm, Non-Locking
V30 ST224 ...	3.0 x 24mm, Non-Locking
V30 ST226 ...	3.0 x 26mm, Non-Locking
V30 ST228 ...	3.0 x 28mm, Non-Locking
V30 ST230 ...	3.0 x 30mm, Non-Locking

CoLink™ Plate Screw Locking

CATALOG NO	DIA x LENGTH, STYLE
V35 ST208 ...	3.5 x 8mm, Non-Locking
V35 ST210 ...	3.5 x 10mm, Non-Locking
V35 ST212 ...	3.5 x 12mm, Non-Locking
V35 ST214 ...	3.5 x 14mm, Non-Locking
V35 ST216 ...	3.5 x 16mm, Non-Locking
V35 ST218 ...	3.5 x 18mm, Non-Locking
V35 ST220 ...	3.5 x 20mm, Non-Locking
V35 ST222 ...	3.5 x 22mm, Non-Locking
V35 ST224 ...	3.5 x 24mm, Non-Locking
V35 ST226 ...	3.5 x 26mm, Non-Locking
V35 ST228 ...	3.5 x 28mm, Non-Locking
V35 ST230 ...	3.5 x 30mm, Non-Locking
V35 ST232 ...	3.5 x 32mm, Non-Locking
V35 ST234 ...	3.5 x 34mm, Non-Locking
V35 ST236 ...	3.5 x 36mm, Non-Locking
V35 ST238 ...	3.5 x 38mm, Non-Locking
V35 ST240 ...	3.5 x 40mm, Non-Locking

CoLink™ Transverse Screw

CATALOG NO	DIA x LENGTH, STYLE
V30 ST418	3.0 x 18mm, Transverse
V30 ST420	3.0 x 20mm, Transverse
V30 ST422	3.0 x 22mm, Transverse
V30 ST424	3.0 x 24mm, Transverse
V30 ST426	3.0 x 26mm, Transverse
V30 ST428	3.0 x 28mm, Transverse

CoLink™ Transverse Screw cont.

CATALOG NO	DIA x LENGTH, STYLE
V30 ST308 ...	3.0 x 8mm, Locking
V30 ST310 ...	3.0 x 10mm, Locking
V30 ST312 ...	3.0 x 12mm, Locking
V30 ST314 ...	3.0 x 14mm, Locking
V30 ST316 ...	3.0 x 16mm, Locking
V30 ST318 ...	3.0 x 18mm, Locking
V30 ST320 ...	3.0 x 20mm, Locking
V30 ST322 ...	3.0 x 22mm, Locking
V30 ST324 ...	3.0 x 24mm, Locking
V30 ST326 ...	3.0 x 26mm, Locking
V30 ST328 ...	3.0 x 28mm, Locking
V30 ST330 ...	3.0 x 30mm, Locking

CoLink™ Transverse Screw cont.

CATALOG NO	DIA x LENGTH, STYLE
V35 ST308 ...	3.5 x 8mm, Locking
V35 ST310 ...	3.5 x 10mm, Locking
V35 ST312 ...	3.5 x 12mm, Locking
V35 ST314 ...	3.5 x 14mm, Locking
V35 ST316 ...	3.5 x 16mm, Locking
V35 ST318 ...	3.5 x 18mm, Locking
V35 ST320 ...	3.5 x 20mm, Locking
V35 ST322 ...	3.5 x 22mm, Locking
V35 ST324 ...	3.5 x 24mm, Locking
V35 ST326 ...	3.5 x 26mm, Locking
V35 ST328 ...	3.5 x 28mm, Locking
V35 ST330 ...	3.5 x 30mm, Locking
V35 ST332 ...	3.5 x 32mm, Locking
V35 ST334 ...	3.5 x 34mm, Locking
V35 ST336 ...	3.5 x 36mm, Locking
V35 ST338 ...	3.5 x 38mm, Locking
V35 ST340 ...	3.5 x 40mm, Locking

Sterile Plates - delivered in boxes

Each label indicates specific Plate style and size.



Sterile Screws Tube ID Legend

COLOR CODE:
SCREW STYLE / DIAMETER

Transverse = ●
3.0 Locking / Non-locking = ●
3.5 Locking / Non-locking = ●



Example Screw code designates: Locking 3.0 x 28mm

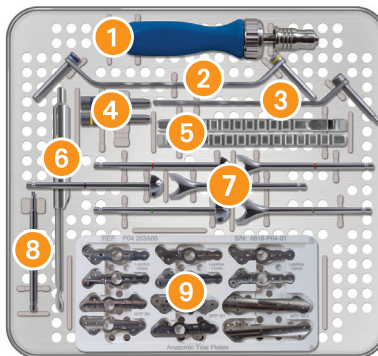

INSTRUMENT TRAY

- 1 Driver Handle
- 2 Color Coded Non-locking Drill Guides
- 3 Transverse Drill Guides
- 4 Color Coded Locking Drill Guides
- 5 Plate Benders
- 6 Depth Gauge
- 7 Cup & Cone Reamers
- 8 T8 Driver
- 9 Plate Trials

PATENT PENDING



A GLOBAL EXTREMITY COMPANY

Corporate Headquarters

In2Bones Global, Inc. • Memphis, TN • USA
844. 602. 6637 • Info@i2b-USA.com

International Office

In2Bones SAS • Lyon • France
+33 (0)4 72 29 26 26

FOLLOW US....



All content contained herein is furnished for informational purposes only. i2b does not recommend a particular surgical product or procedure suitable for all patients. Each surgeon must evaluate the appropriateness of a device and corresponding techniques based on medical training, clinical judgment and surgical experience. The proper surgical technique and/or procedure are the responsibility of the medical professional. Indications, contraindications, warnings, and precautions are listed in implant packaging insert and should be reviewed carefully by the physician and operating room personnel prior to any proposed procedure. • CoLink, the In2Bones name and logo are trademarks or registered trademarks of i2b-USA or its subsidiaries. In2Bones USA Memphis TN, 38119 USA / In2Bones SAS, 69130 Ecully - FRANCE - © 2018 In2Bones USA, Memphis, TN - All rights reserved- CLPST0618 Rev B 1218